

L1A GPS Antenna

中国代表处:

Tel: +86-755-29644311

Fax: +86-755-29644383

Email: sales@gpssource.com.cn

Web: www.gpssource.com.cn

Technical Product Data

Features

- Outstanding Noise Figure, < 1dB
- Excellent Gain, 38dB typ.
- Wide Voltage Range, 3-16VDC
- Tiny Current Draw, < 20mA
- Multiple Connector Options



Description

The L1A is a high performance L1 GPS antenna that is ideally suited for many applications requiring low noise and excellent gain. The product functions to specifications over the entire operational voltage and temperature range at a minimal current draw. The product includes high frequency selectivity to avoid interference with other nearby transmitters.

Electrical Specifications, Operating Temperature -40 to 85°C

Parameter	Conditions	Min	Typ	Max	Units
Frequency Range: (Passband)	Ant – Output, VDC = 3 to 16V, Output = 50Ω	1570	1575	1580	MHz
Out Imped.			50		Ω
Gain Element: LNA	Ant Element LNA, VDC = 3 to 16V, Output = 50Ω	33	3 35	3.5 36	dBiC dB
Output SWR	VDC = 3 to 16V, Output = 50Ω			2.5:1	-
Noise Figure	VDC = 3 to 16V, Output = 50Ω		0.8	1.0	dB
Selectivity +/- 50MHz +/- 100MHz	Ant – Output, VDC = 3 to 16V, Output = 50Ω	-22 -34	-24 -35	-25 -37	dB
Req. DC Input V.	DC Input on RF Output Center Conductor	3		16	VDC
Current-Amplified	Amplifier Current Draw, DC Input		17	20	mA
Polarization	Right Hand Circular				

Performance Data:

Far Field Patterns – 1575 MHz

Rotating Linear – (E Cut)

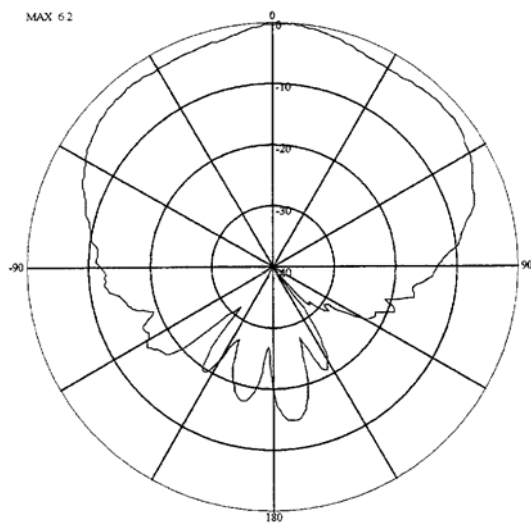

Rotating Linear – (H Cut)

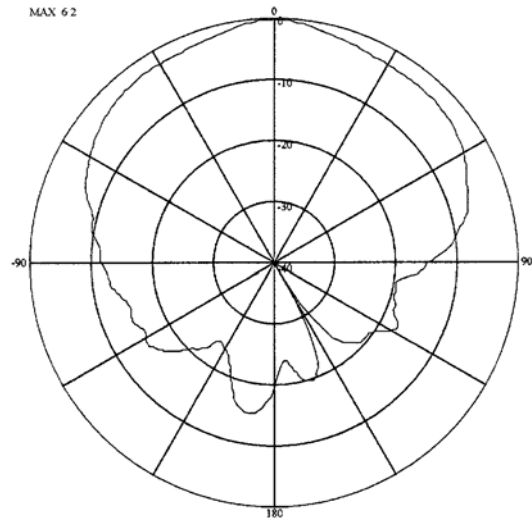

Far Field Patterns – 1575 MHz

Azimuth Cuts:

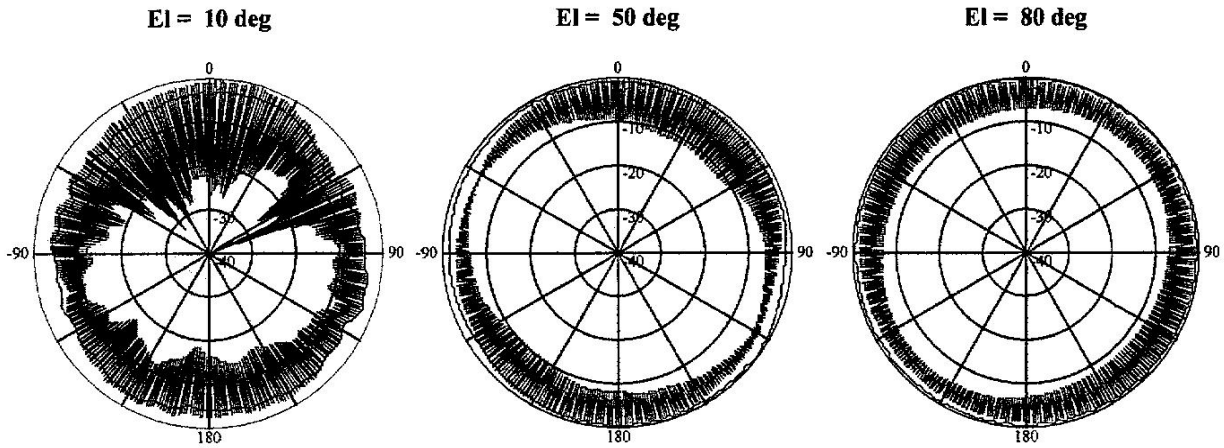

LNA Frequency Response

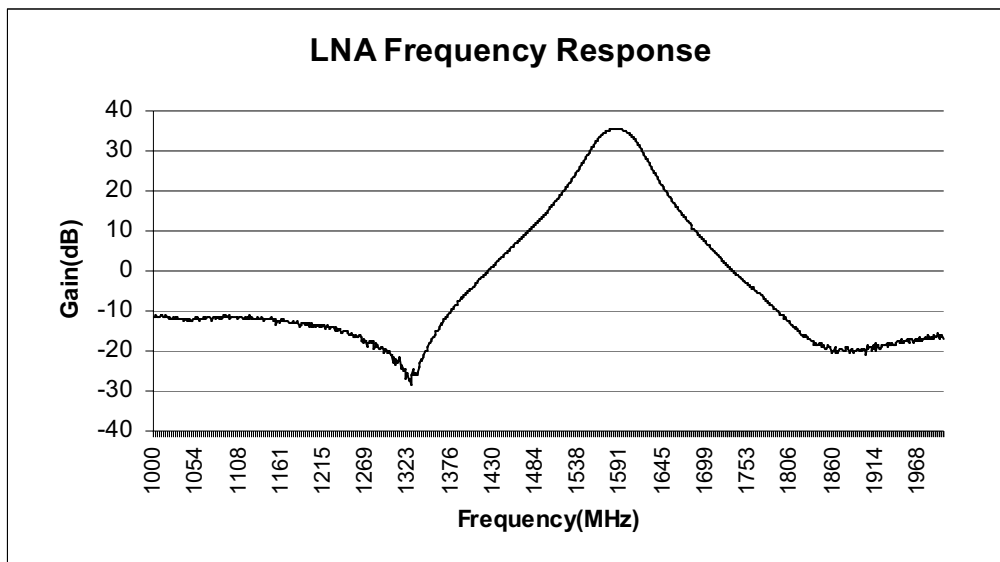

Notes:

Frequency selectivity of antenna element adds additional out of band rejection.

Available Options:

Power Supply Options:		
Source Voltage Options	Voltage Input	Type
	DC 3-16 VDC	Input on Center pin of RF Connector.
RF Connector Options:		
Connector Options	Connector Type	Limitations
	N (Female)	
	SMA (Male & Female)	
	TNC (Female)	
	SMB (Female)	Future – not ava. at this time
	SMC (Female)	Future – not ava. at this time
	MCX (Female)	Future – not ava. at this time
Mounting Option:		
	“L” Bracket Pole Mount HW	See Figure below

Notes: None

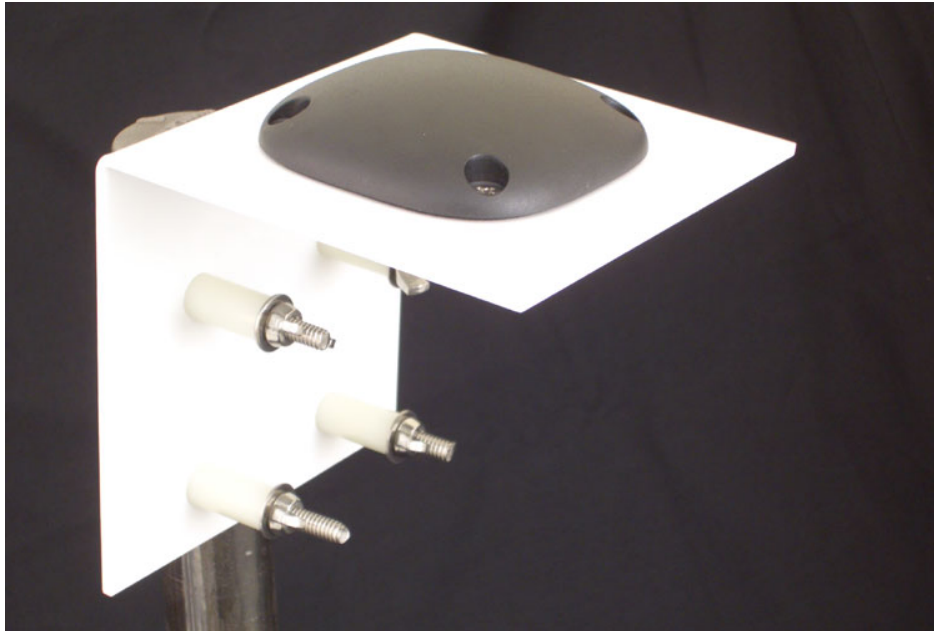

Figure 1. “L” Bracket Pole Mount HW



Your source for quality GNSS Networking Solutions and Design Services, Now!

Part Number:

L1A - PM - NF

Product:

Standard GPS L1
Amplified Antenna

Pole Mount Option:

Connector Options:

- NF** – N, Female
- SM** – SMA, Male
- SF** – SMA, Female
- TF** – TNC, Female
- SB** – SMB Jack, Female (Future – not available at this time)
- SC** – SMC Jack, Female (Future – not available at this time)
- MX** – MCX Jack, Female (Future – not available at this time)

